

The MCT-24DHRD Series

Dual & Single In Line Package (SIL & DIL)
Digital Temperature & Pressure Outputs
I²C & SPI Protocols

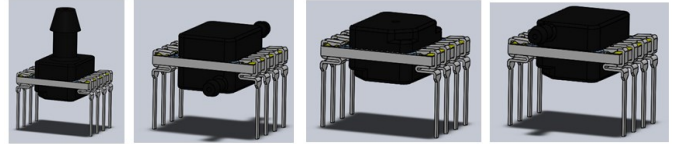

DESCRIPTION

Advanced Sensors Multi Chip Technology (MCT) 24DHRD Series incorporates a bonded silicon gage to the latest mixed signal ASIC (Application Specific Integrated Circuit) with a leading 24Bit High Resolution ADC ($\Sigma \Delta$) specifically designed for medical, life science and avionic control industries. The MCT 24DHRD Series provides a 24bit digital pressure and 16 bit digital temperature output in SPI and I²C protocols. The advanced design requires no external calculation since a fully integrated digital signal processor (DSP) performs an error correction algorithm. The designs superior performance provides 1% Total Error across a wide temperature range of -10 to 85° Given these features and an advanced low power design; the MCT-24DHRD series is the ideal choice for OEM customers.

APPLICATIONS

- Avionic Instrumentation
- Automotive diagnostics
- Medical equipment/instrumentation
- Air Speed and Altitude
- Environmental controls
- Barometric pressure measurement
- Factory Automation
- Process Controls

FEATURES

- Internal Error Correction
- Low Power Sleep Stage
- Highly Accuracy
- Wide Supply Voltage
- High Resolution Digital Output (24bit Pressure, 16bit Temperature)
- I²C & SPI Outputs
- Custom Outputs and Ranges Available

SPECIFICATIONS

	Symbol	Min	Typical	Max	Unit	Note
Performance Specifications						
Supply Voltage		1.6	3.3	3.60	V	
Current Consumption				3	mA	
Standby Current			0.2		µA	
Pressure Resolution				24	bits	
Temperature Resolution				16	bits	
Output (Type 1) at Pmin			-6710886		cts	
Output (Type 1) at Pmax			+6710886		cts	
Output (Type 2) at Pmin			-7549747		cts	
Output (Type 2) at Pmax			+7549747		cts	
Pressure Accuracy		-0.5		0.5	mA	2
Total Error Band	TEB	-1.0		1.0	%FSS	3
Temperature Accuracy			1.5		°C	
Long Term Stability			±0.4		%FSS	
Conversion Time			1.0		mS	4
Power On to Valid Data				<10	mS	5
Weight				3	grams	
Compensated Temperature			-10 to 85		°C	6
Operating Temperature			-40 to 125		°C	6

SPECIFICATIONS	Symbol	Min	Typical	Max	Unit	Note
Absolute Maximum Conditions						10
Supply Voltage		-		3.65	V	
Storage Temperature		-50		150	°C	
Package Integrity, Common Mode				300	psi	7
Proof Pressure				3x		8
Burst Pressure				5x		9
Media Compatibility		CDA, Non Ionic, Non Corrosive Gases				
Wetted Materials		Ceramic, RTV, Epoxy, Silicon, Gold, Aluminum, LCP				

Reference Conditions: Vsupply: 3.30Vdc Ta=25 °C, Positive Pressure Port A

1. All specification at reference conditions unless otherwise noted.
2. Maximum deviation from a Best Fit Straight Line through Pmin and Pmax measured at 25 °C. Errors included Pressure Non Linearity, Pressure Hysteresis and Repeatability.
3. Maximum deviation from the Ideal Transfer Function expressed as a percentage of the %FSS over the compensated temperature range. Includes calibration errors (Offset & Span), temperature errors (Offset & Span), pressure non-linearity, pressure and thermal hysteresis. TEB Errors for mBar Ranges below
4. The time for the output DAC to be updated with new data.
5. The time for the output DAC to have valid data after a power on reset.
6. Compensated and operating temperature for mBar ranges are 0 °C to 60 °C and -20 °C – to 105 °C, respectively.
7. Maximum pressure the sensor package can withstand without rupture.
8. Maximum pressure without degrading sensor’s performance specifications.
9. Maximum pressure the silicon diaphragm can withstand without rupture.
10. Exceeding Absolute Maximum Specification may damage the device. Extended exposure beyond the operating conditions may affect device reliability.

PRESSURE AND TEMPERATURE TRANSFER FUNCTIONS

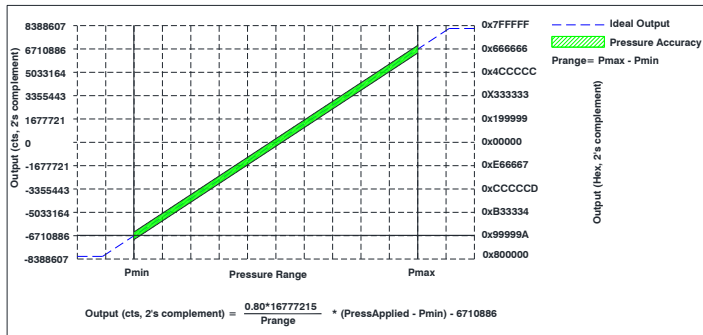

Type 1, 10-90%, Pressure Transfer Function

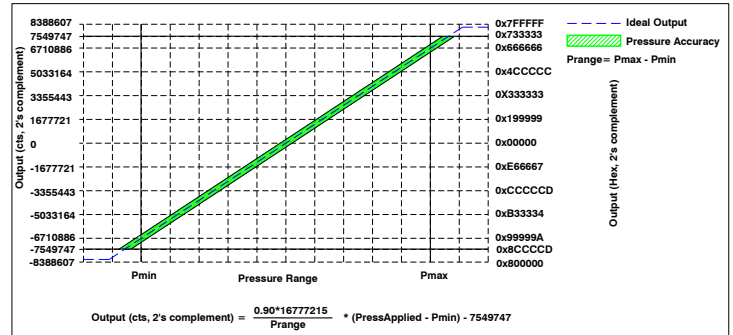

Type 2, 5-95%, Pressure Transfer Function

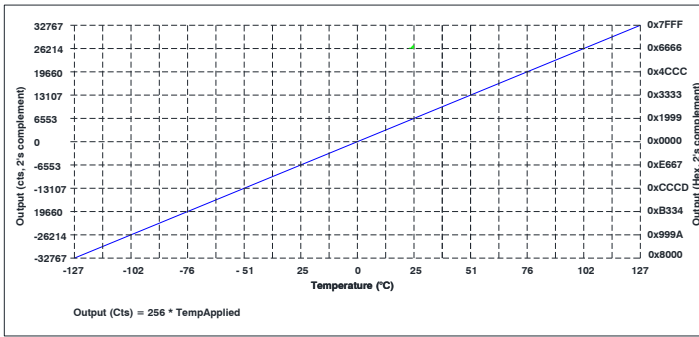

Temperature Transfer Function

CONNECTION DIAGRAM

Pin	1	2	3	4	5	6	7	8
I2C/SPI	GND	SUPPLY	SDA/MOSI	SCL/SCLK	SS	NA	NA	/MISO

MECHANICAL DIMENSIONS in [mm]

DUAL IN LINE, THRU HOLE

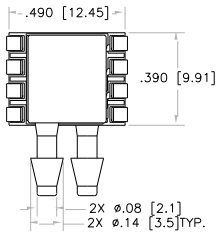

HORIZONTAL BARB, DUAL

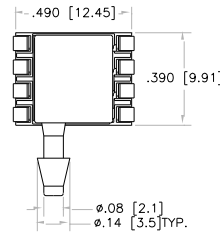

HORIZONTAL BARB, TOP

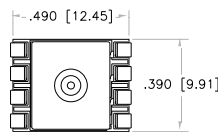
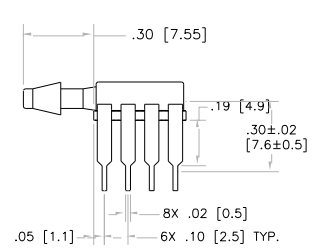
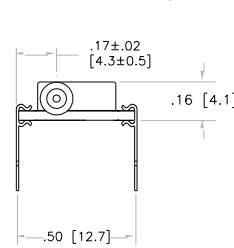
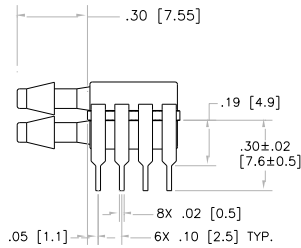
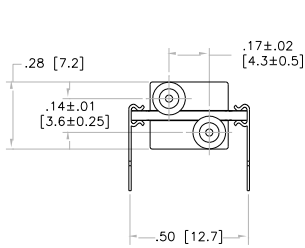

VERTICAL BARB, TOP

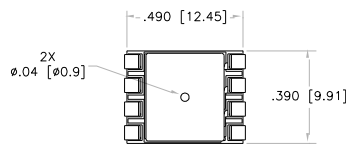

VERTICAL HOLE, DUAL

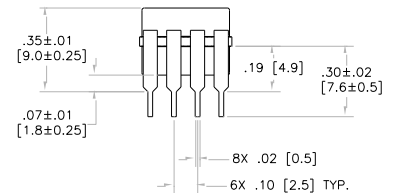
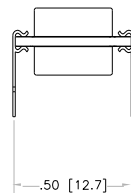
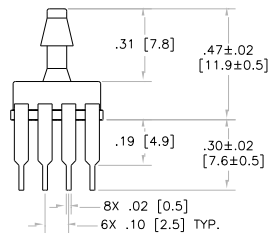
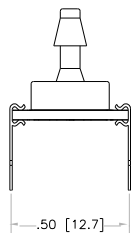

DUAL IN LINE, J LEAD SMT

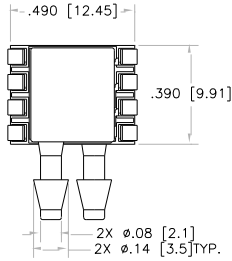

HORIZONTAL BARB, DUAL

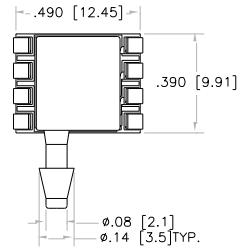

HORIZONTAL BARB, TOP

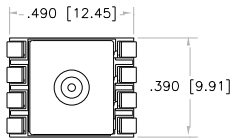
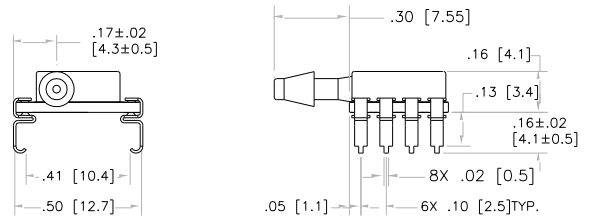
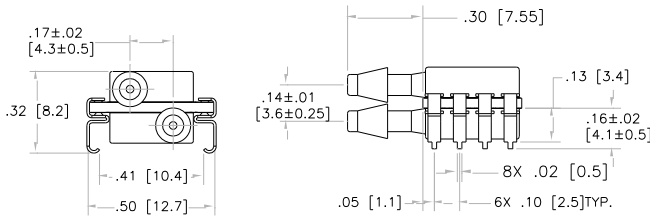

VERTICAL BARB, TOP

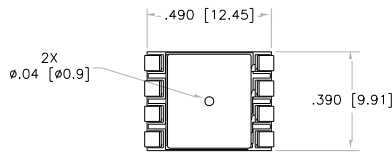

VERTICAL HOLE, DUAL

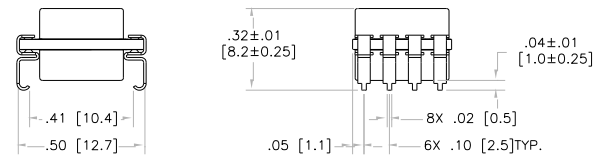
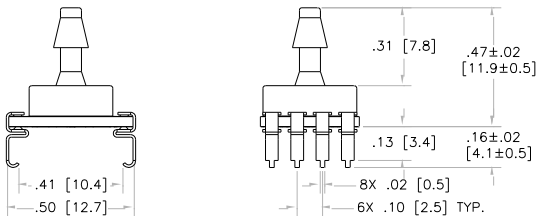

LEADLESS CHIP CARRIER, CASTELLATION

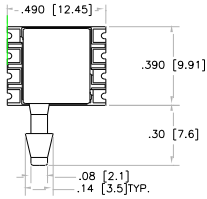

HORIZONTAL BARB, TOP

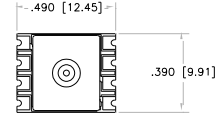

VERTICAL BARB, TOP

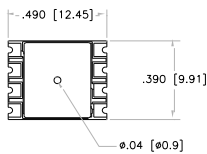
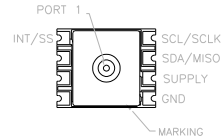
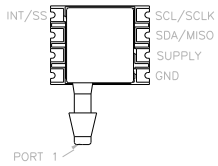
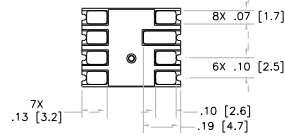
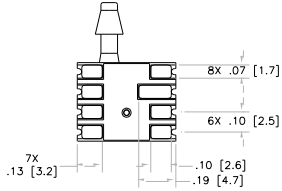
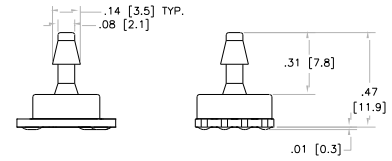
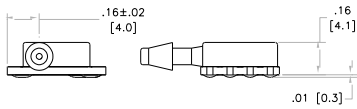

VERTICAL HOLE, SINGLE

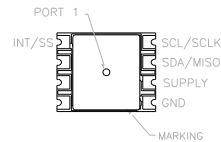
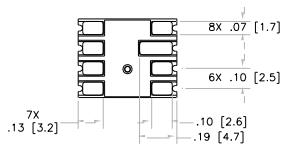

SINGLE IN LINE, S & SL LEAD

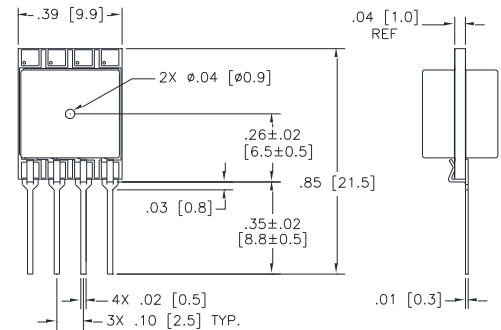
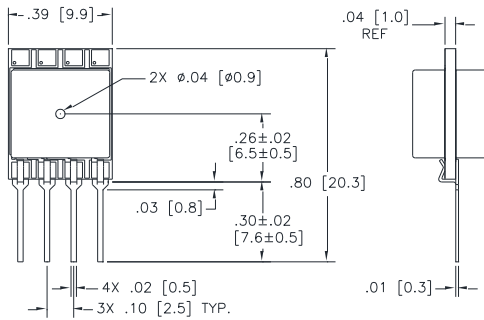

VERTICAL HOLE, DUAL
S PIN STYLE

VERTICAL HOLE, DUAL
SL PIN STYLE

VERTICAL HOLE, DUAL,
S/SL PIN STYLE

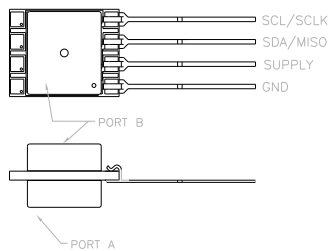

PART NUMBERING FOR ORDERS

Series	Port Type	Package Style	Pressure Range	Pressure Units	Pressure Type (Range Availability) [Package Availability]	Calibrated Voltage	Output Type	Digital Protocol
MCT-24DHRD	VHD=Vertical Hole, Dual	J= J lead SMT	005	M=mBar	G= Gage (All Ranges) [All Port Types]	3=3.3Vdc 5=5.0Vdc	Type1= 10 -90% of Cts (24 Bits)	I1=I2C, 0x28H I2=I2C, 0x38H I3=I2C, 0x48H [All Packages]
			010					
			020					
	HBD=Horizontal Barb, Dual	T= DIL Thru Hole	050	P=PSI	A=Absolute (15 -150PSI) [All Port Types]		Type2= 5 -95% of Cts (24 Bits)	S1=SPI [No S Pin Type]
			100					
			200					
	VBT=Vertical Barb, Top	S=SIL (I2C Only)	001	B=Bidirectional (All Ranges) [All Port Types]				
			002					
			005					
	HBO=Horizontal Barb, Opposing	C=LLC	015	B=Bar				
			030					
			050					
	HBT=Horizontal Barb, Top		100					
150								
001								
VHS=Vertical Hole, Single		002						
		003						
		006						

Part Number Example: MCT-24DHRD VBTJ005PB31S1 Vertical Barbed Top Port, J Leaded SMT Package, -5 to +5 PSI Range, 3.3Vdc Supply, SPI Protocol, Pmin=-5, Pmax+= 5 PSI

WARRANTY

Pressure sensors have a limited one-year warranty to the original purchaser. AVSensors will repair or replace, at its option, without charge those items it finds defective. This is the buyers sole remedy and is in lieu of all other warranties, expressed or implied, including those of merchantability and fitness for a particular purpose. In no event shall AVSensors be liable for consequential, special, or indirect damages. This warranty does not apply to units that have been modified, misused, neglected or installed where the application exceeds published ratings. Specifications may change without notice. The information supplied is believed to be accurate and reliable as of this printing, however, we assume no responsibility for its use.